

ARQUILED

ARQUICITY C8



Name Arquicity C8
Description Arquicity is a luminaire developed for public road lighting. This luminaire was developed for direct replacement of the installed equipment. It is called LOW-LOST, because it was carefully developed by Arquiled so that it would have a low manufacturing cost, as well as low installation, operation and maintenance costs for the Client. The luminaire possesses a compact body, built in a specific aluminium alloy, with a thermal dissipation 12% higher in relation to traditional alloys. It comes with an anodized finishing of high resistance, capable of withstanding severe operating conditions such as maritime environments (RIØ and blistering zero mm at 1600 hours in a chamber of saline fog according to the ISO 7253 norm). The cover of the luminaire does not interfere with light diffusion, being made of tempered crystal glass with high resistance to impacts. Equipped with the most advanced technology available for the control of the SSL (Solid State Lighting), this luminaire includes as standard equipment a temperature sensor designed to assure the longevity of the LED, in other words, if the luminaire is turned on when the necessary conditions for proper LED functioning are not met (excessive heat) this sensor will not allow the control driver to order an "on" status.

Light source	72x High power LED Golden Dragon Plus - Osram Opto Semiconductors
Beam angle	170°
Color temperature	3200K, 4500K, 6500K
Luminous Flux	9360lm
Total led power	92W
Illuminance	25~30 lux/8m
Input Voltage and Frequency	100~265V AC, 50/60Hz
Working current	350mA
Installation tube diameter	Ø50mm (Min) to Ø70mm (Máx.)
Option	Tractus Sensor®; G-Sensor®; FOG-Sensor®; ARQNET® protocol.

ARQUILED

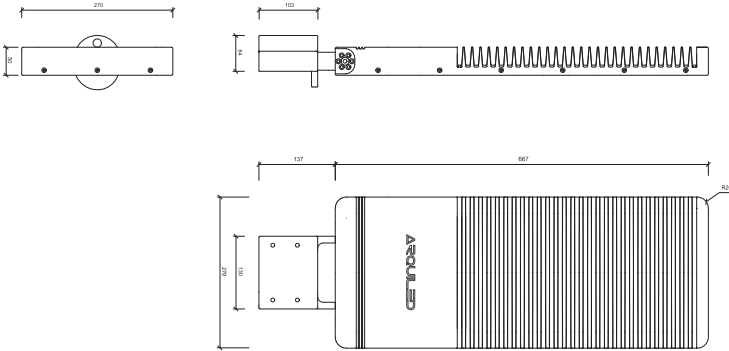
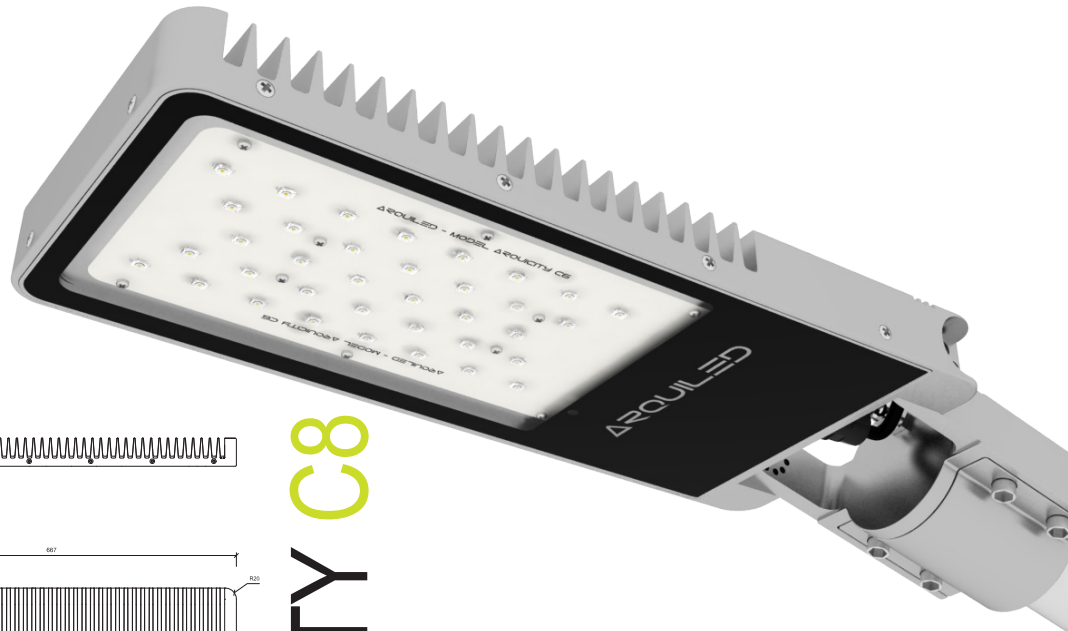

ARQUICITY C8

For the energy rationalization to be effective, our Engineering Department has developed a set of optional modules, which allow an additional optimization of the luminaire's performance:

- **Tractus Sensor®** - control module that allows volumetric detection and respective automatic regulation/control of the luminous flow through FSK technology. In other words, this sensor will manage the luminous flux according to the road usage and human presence. The luminaire can be programmed to produce a reduced luminous flux, from a particular time of night onwards or in continuous mode, and when road and/or human activity is detected it will fade-in and fade-out to a predefined maximum target. This module allows significant reductions in energy consumption, since road and/or human activity is very low during a large part of the operating time frame.
- **Thermal Sensor®** - the LED module is protected with a thermal sensor for outside temperature evaluation, strategically placed on the MCPCB. This sensor will protect the technology against erroneous turn ons, for example due to malfunctions of crepuscular cells during daytime. If the temperature is excessive (above 70°C), the circuit opens preventing the deterioration of the SSL technology.
- **SUN SENSOR II®** - the luminaire is prepared to receive a cell that informs about the status of ambient lighting. Using this cell, the need for control system or remote drive is eliminated, since the luminaire will automatically turn on when the medium ambient light level is below a certain value, ie, at night.
- **FOG SENSOR®** - the luminaire is prepared to receive a fog sensor, which in the presence of fog, will commute from the primary circuit of white colour to a secondary circuit of amber colour LEDs, in order to improve visibility in these conditions. This sensor was developed for application in frequent fog areas.

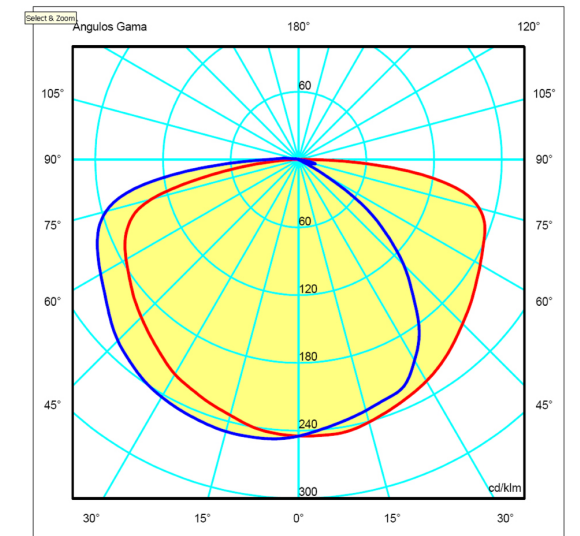

- **G-SENSOR®** - the luminaire is prepared to receive a stability sensor, which will send warning information in case the luminaire is overthrown or simply suffers an impact of any dimension, such as a traffic accident that throws down or deforms the post, removing the verticality, or strong winds that may swing the post momentarily. The latter can result in a signal to weather authorities informing about the presence of strong winds.

When remotely controlled, the luminaire is prepared to communicate through tone signals, or with any other method using PLC (Power Line Communications). This communication will be based on the ARQNET® communications protocol, developed by our Engineering Department. The luminaire is also prepared for communication with the future INOVGRID system. (Portuguese energy utility system).

